



'basic' bi-directional ball valve

Female threaded outlet - single acting spring return actuator - PTFE

ITEM 661



REFERENCE	DESCRIPTION	Net weight	Volumen (m ³)	Gross weight	Unidades lote
111D510	BALL VALVE SIMP.ACT.PNEUM.ACCT.F/T.OUT. 20	1.616	0.01553	1.9427	1
111D511	BALL VALVE SIMP.ACT.PNEUM.ACCT.F/T.OUT. 25	1.6755	0.02243	2.1632	1
111D512	BALL VALVE SIMP.ACT.PNEUM.ACCT.F/T.OUT. 32	1.8504	0.03129	2.4234	1
111D513	BALL VALVE SIMP.ACT.PNEUM.ACCT.F/T.OUT. 40	2.814	0.03129	3.387	1
111D514	BALL VALVE SIMP.ACT.PNEUM.ACCT.F/T.OUT. 50	3.0855	0.03129	3.6585	1
111D515	BALL VALVE SIMP.ACT.PNEUM.ACCT.F/T.OUT. 63	3.672	0.03648	4.266	1
111D516	V.BOLA BIDIREC. ACT. NEUM. S/E R/H 75	5.711	0.0446	6.405	1
111D517	V.BOLA BIDIREC. ACT. NEUM. S/E R/H 90	11.61	0.0446	0	1

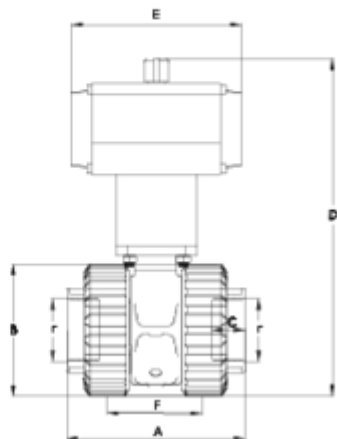

ITEM 661 | Female threaded outlet - single acting spring return actuator - PTFE

CODIGO	r	Actuador	PESO (g)	DN	A	B	C	D	E	F	PN	TIPO ROSCA
11D510	1/2"	H050SE	1380	15	86	55	17	192	138	44	PN16	BSP
11D511	3/4"	H050SE	1424.2	20	99	62	20	197	138	49	PN16	BSP
11D512	1"	H050SE	1561.1	25	122	72	23	208	138	66	PN16	BSP
11D513	1 1/4"	H063SE	2419.85	32	131	88	26	248	155	71	PN16	BSP
11D514	1 1/2"	H063SE	2698.24	40	155	103	33	265	155	75	PN16	BSP
11D515	2"	H063SE	3252	50	180	120	29	307	155	89	PN16	BSP
11D516	2 1/2"	H075SE	6080	65	202	150	33	376	210	119	PN10	BSP
11D517	3"	H100SE	11180	80	232	181	36	426	280	140	PN10	BSP



Product Documents



Product Certificates

Company Certificates

