



'basic' bi-directional ball valve

Thermofusion outlet - single acting spring return actuator - FPM

ITEM 692



REFERENCE	DESCRIPTION	Net weight	Volumen (m ³)	Gross weight	Unidades lote
111D720	FPM BALL V.SING.ACT.PNEU.ACCT.THERMO FUS.OUT. 20	1,6203	0,03648	1,6203	1
111D721	FPM BALL V.SING.ACT.PNEUM.ACCT.THERMO FUS.OUT.25	1,6675	0,03648	1,6675	1
111D722	FPM BALL V.SING.ACT.PNEUM.ACCT.THERMO FUS.OUT.32	1,8555	0,03648	1,8555	1
111D723	FPM BALL V.SING.ACT.PNEUM.ACCT.THERMO FUS.OUT.40	2,716	0,03648	2,716	1
111D724	FPM BALL V.SING.ACT.PNEUM.ACCT.THERMO FUS.OUT.50	3,0555	0,04460	3,0555	1
111D725	FPM BALL V.SING.ACT.PNEUM.ACCT.THERMO FUS.OUT.63	3,602	0,04460	3,602	1
111D726	V.B BID.ACT.N S/E S/TERMO 75 FPM	5,568	0,02243	0	1
111D727	V.B BID.ACT.N S/E S/TERMO 90 FPM	11,43	0,02243	0	1



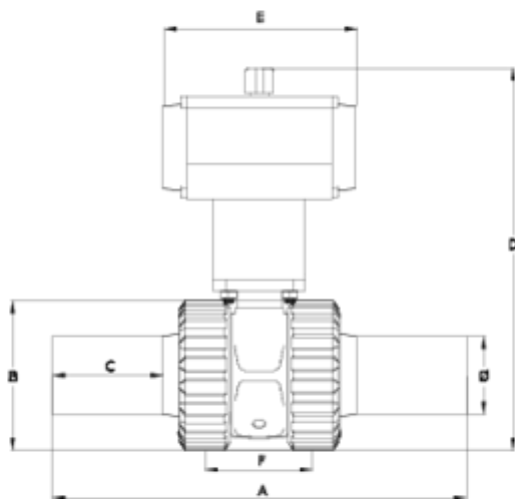

ITEM 692 | Thermofusion outlet - single acting spring return actuator - FPM

CÓDIGO	f	Actuador	PESO (g)	DN	A	B	C	D	E	F	PN	MEDIDA
11D720	20	H050SE	1386	15	212	55	65	192	138	44	PN16	MÉTRICO
11D721	25	H050SE	1428.92	20	221	62	65	197	138	49	PN16	MÉTRICO
11D722	32	H050SE	1558.8	25	256	72	70	208	138	66	PN16	MÉTRICO
11D723	40	H063SE	2418.7	32	261	88	70	248	155	71	PN16	MÉTRICO
11D724	50	H063SE	2675.84	40	285	103	79	265	155	75	PN16	MÉTRICO
11D725	63	H063SE	3139.8	50	327	120	89	307	155	89	PN16	MÉTRICO
11D726	75	H075SE	6020	65	369	150	91	376	210	119	PN10	MÉTRICO
11D727	90	H100SE	11050	80	410	181	100	426	280	140	PN10	MÉTRICO



Product Documents



Product Certificates

Company Certificates

